



# LUNA<sup>®</sup> X5

SHAPING THE FUTURE OF CARE

DESIGN . SIMPLICITY . MAXIMIZED VALUE . SUSTAINABILITY



## Discover LUNA<sup>®</sup> X5

LUNA<sup>®</sup> X5 is designed for **discreet, elegant, and seamless integration** into any care environment. Its all-in-one concept (fixed, portable & multiple lifting capacity module) and **high lifting range** offer long-term flexibility.

Its **intuitive operation** simplifies daily use for caregivers and technical teams while **maximizing resident safety and comfort**.

Built for **durability and minimal maintenance**, LUNA<sup>®</sup> X5 **reduces total cost of ownership**. The unique ecodeSIGN and the use of recycled aluminum tracks significantly reduce **environmental impact**.

### Technical specifications

**Max. capacity:** 150, 200 or 275 kg

**Lifting range:** 2500 mm

**Weight:** 5.2 kg without spreader bar

**Measurements:** Ø 320 x H 130 mm

**Battery:** 36V NiMH | **Charging:** 100-240V, 0,3A

**Cover:** High impact, moulded ABS

**Noise:**

- LwA during lifting/lowering without load is 49dB(A)
- LwA during lifting/lowering with 175 kg load is 53dB(A)

**Charging time:** Approx. 5 hours to fully charge empty battery

**Lifting/lowering speed:**

- 42 mm/sec. with 15-275 kg load
- 90 mm/sec. with 0-15 kg load

**Number of lifts on a fully charged battery:**

Approx. 85 lifting cycles with 90 kg

**Protection class:**

- Lifting module: IPX4
- Hand control: IPX7

**Expected lifetime:** 20 years or 30.000 lifts

**5-year warranty**

### Key features and benefits



#### Unique and elegant

- ▶ **All-in-one lift:** fixed and portable mode with adjustable lifting capacities (150, 200, 275 kg) combined in one single product.
- ▶ **Unparalleled lifting height:** new system lift & bayonet design, with high reach lifting strap (2500mm).
- ▶ **In-Track Charging (ITC) capability:** Always ready for use and easy to retrofit



#### Simple, safe and smooth to use for enhanced care

- ▶ **Intuitive:** quick-reach emergency stop and emergency lowering button directly integrated to the hand control.
- ▶ **Embedded safety:** patented spreader bar hooks for safe attachment of slings. The spreader bar hooks are designed to close automatically under the resident's weight.
- ▶ **Staff adoption and usage monitoring:** service data tool enabling to extract real-time usage data (emergency stop usage, discharges, service, etc.).



#### Built to last for optimized Total Cost of Ownership and return on investment

- ▶ **Durable, high quality and repairability components for reliability and low Total Cost of Ownership (TCO).**
- ▶ **Exclusive smart maintenance system** for hand control: easily replaceable hook and cable.
- ▶ **Fast lift maintenance**, in less than 5 minutes with only 1 tool.
- ▶ **Service indicator on the side panel.**



#### The first system designed for sustainability

- and reduced environmental impact.
- ▶ **Made of minimum 75% recycled aluminum**, reducing scope 3 carbon footprint by 66%.
- ▶ **EcodeSigned lift.**



## Dimensions

Same measurements for both fixed and portable mode

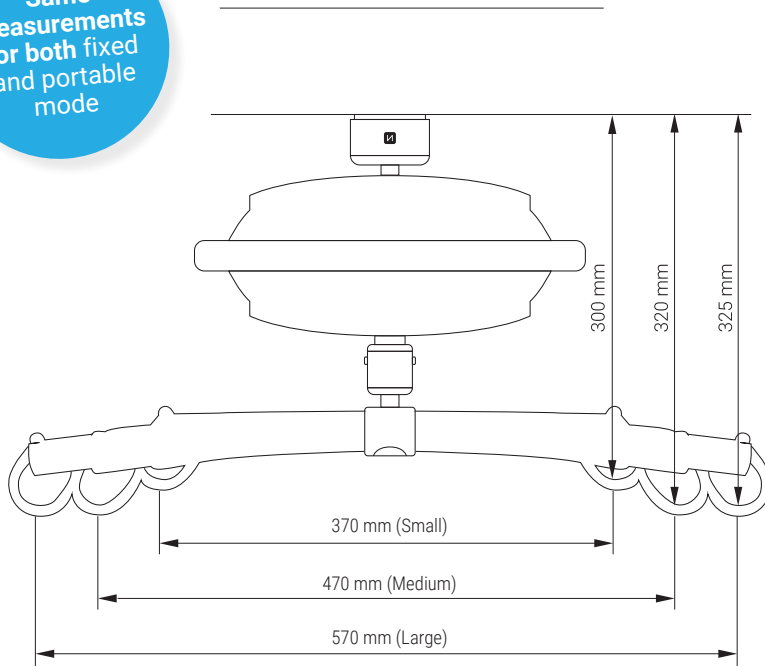

## Item numbers

Product	Item number
<b>LUNA® X5</b>	Item no. : 015-03050 UDI : 05740008102836
<b>Hand control</b> (1 channel) with 1080 mm cable	017-00320
<b>Hand control</b> (1 channel) with 1320 mm cable	017-00321
<b>Hand control</b> (2 channel) with 1080 mm cable	017-00322
<b>Hand control</b> (2 channel) with 1320 mm cable	017-00323
<b>Charging station incl. charger</b>	017-00300XX*
<b>Spreader bar, size S</b>	017-00335
<b>Spreader bar, size M</b>	017-00336
<b>Spreader bar, size L</b>	017-00337
<b>Spreader bar, 3-point</b>	017-00338
<b>Holder for spreader bar</b>	016-02230
<b>Charger LUNA® X5</b> (for NiMH batt./1.8m DC cable)	017-00302XX*

\* EU, UK, AUS or US plug



**Our signature elegant & discreet design, enhanced with new generation features and benefits.**

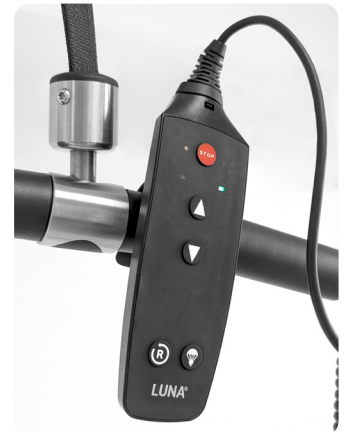

**User friendly hand control with emergency stop button within reach and exclusive smart maintenance system.**



**Wall charging station, designed so that the hand control stays in place.**



EU 2017/745  
Class I

For further specifications, please contact [export@winnocare.dk](mailto:export@winnocare.dk).  
All figures and measurements are indicative and may vary in certain usage situations.  
Winnocare reserves the right to make changes without prior notice. Images may include accessories.