

Technical Manual

AERYS Medical Beds

- ❶ Head panel,
- ❷ Back rest,
- ❸ Angled lifting pole slots,
- ❹ IV stand slots,
- ❺ Bed base,
- ❻ Mattress retainer,
- ❼ Foot panel,
- ❽ Head cross brace,
- ❾ Foot cross brace,
- ❿ Wheels,
- ⓫ Leg rest with folding mechanism,
- ⓬ Frame.

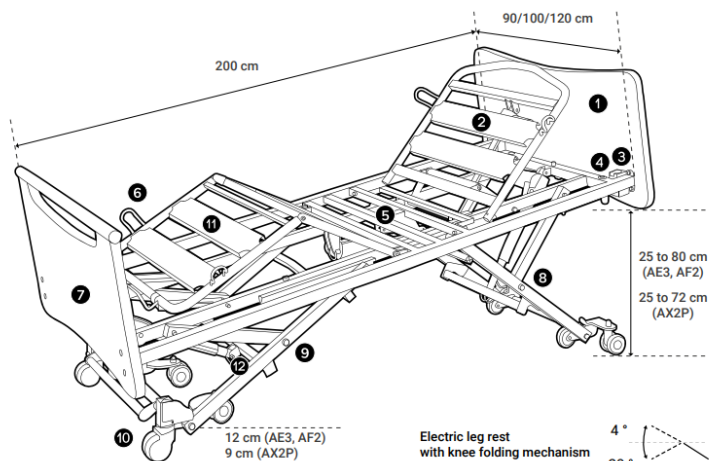

TM_AERYS_EN
25/10/2024

TABLE OF CONTENTS

TRANSPORT AND STORAGE.....	- 3 -
ELECTRICAL CHARACTERISTICS	- 3 -
Electrical data	- 3 -
Electromagnetic compatibility	- 3 -
Equipotentiality	- 5 -
TECHNICAL CHARACTERISTICS.....	- 5 -
Noise	- 5 -
Electrical components	- 6 -
COMPATIBLE MATTRESSES	- 6 -
ELECTRICAL CONNECTION DIAGRAM	- 7 -
REMOTE CONTROL AERYS.....	- 7 -
Customised variable height position	- 7 -
Remote control functions.....	- 7 -
Lock remote control functions	- 8 -
Reset of the AERYS bed without lateral displacement	- 8 -
Reset of the AERYS bed with lateral displacement.....	- 9 -
Option	- 9 -
INSTALLING ACCESSORIES AND SPECIAL FEATURES	- 10 -
Barriers, SAM, and accessories.....	- 10 -
Wall stop A670-00 without breaking (AERYS & AERYS COMFORT)	- 10 -
Wall stop A670-00B with optional masked wheels (AERYS & AERYS COMFORT).....	- 10 -
Wall stop A663-00 (AERYS XXL)	- 11 -
Trendelenburg / back tilt.....	- 11 -
Power supply unit initialization	- 13 -
Electrical system initialization (all options without side shift option)	- 13 -
Electrical system initialization (option T).....	- 13 -
Use of night light (option J)	- 13 -
Angle lifting pole and IV stand.....	- 14 -
TROUBLESHOOTING GUIDE	- 15 -
MAINTENANCE	- 17 -
Identification	- 17 -
Instructions for dismantling the motors.....	- 17 -
Maintenance	- 18 -
Medical beds control sheet	- 19 -
Cleaning and disinfection	- 20 -
SCRAPPING	- 21 -
SPARE PARTS.....	- 21 -

TRANSPORT AND STORAGE

For transport, the bed should be in its low position, and strapped and protected. The wired control and supply lead should be attached to the bed base.

The head and foot boards are protected and strapped to the sleeping surface.

The bed should be transported upright when in its original packaging in compliance with the instructions printed on the packaging.

Warning: It is strictly forbidden to stack packages weighing over 60 kg/m², whatever the position they are in.

Before transporting or dismantling the bed, make sure the back and leg rests are fixed to the frame of the bed base.

ELECTRICAL CHARACTERISTICS

ELECTRICAL DATA

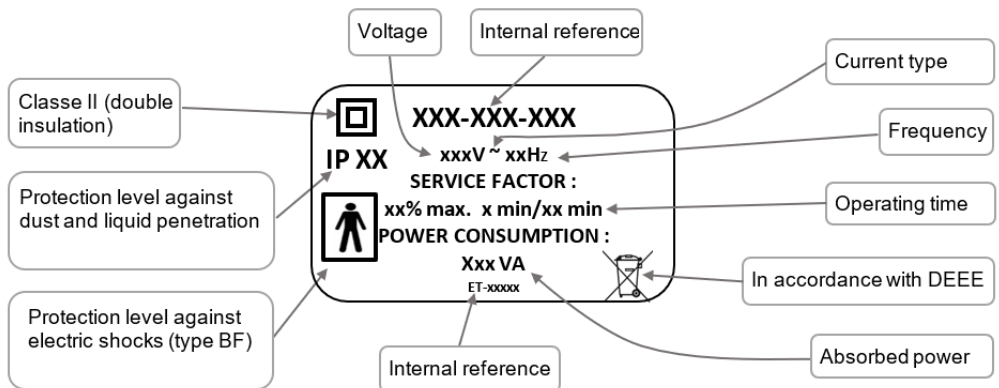

ELECTROMAGNETIC COMPATIBILITY

Warning: The bed is an electromedical device requiring special precautions with regard to electromagnetic compatibility. The device must be installed and put into service according to the electromagnetic compatibility information provided in this technical manual.

Warning: The use of accessories, transducers, and cables other than those specified or supplied by the manufacturer may cause increased electromagnetic emissions or a decrease in the immunity of the device and may cause improper operation.

The bed will not move automatically when subject to electromagnetic disturbances within the limit of the values indicated below:

Manufacturer's declaration and guide – Electromagnetic emissions		
The medical bed (see references in contents) has been designed for use in the electromagnetic environment specified below. The user should ensure that it is used in such an environment.		
Emissions test	Compliance	ELECTROMAGNETIC ENVIRONMENT - GUIDE
RF emissions CISPR 11	Group 1	The medical bed (see references in contents) uses RF energy only for its internal functions. Therefore, its RF

		emissions are very low and are not likely to cause any interference in nearby electronic equipment.
RF emissions CISPR 11	Class B	The medical bed (see references in contents) can be used in all domestic environments, including those directly connected to the public low-voltage power supply network that supplies buildings for domestic purpose. []
Harmonic emissions EN 61000-3-2	Class A	
Voltage fluctuations / Flicker EN 61000-3-3	Compliant	
RF emissions CISPR 14-1	Not Applicable	The medical bed (see references in contents) has not been designed for connection to other equipment.
Manufacturer's declaration and guide - electromagnetic immunity		
The medical bed (see references in contents) has been designed for use in the electromagnetic environment specified below. The user should ensure that it is used in such an environment.		
IMMUNITY TEST	IEC 60601 Severity level	COMPLIANCE LEVEL
Electrostatic discharge EN 61000-4-2	± 8 kV contact ± 15 kV air	± 8 kV contact ± 15 kV air
Radiated RF EN 61000-4-3	3 V/m 80Mhz – 2,7Ghz 80% AM at 1kHz	3 V/m 80Mhz – 2,7Ghz 80% AM at 1kHz
Proximity fields from RF wireless communication equipment EN 610004-3	See table below	See table below
Electrical fast transients EN 61000-4-4	± 2 kV for feeders ± 1 kV for input/output lines Repetition frequency at 100 kHz	± 2 kV for feeders ± 1 kV for input/output lines Repetition frequency at 100 kHz
Surges EN 61000-4-5	Differential mode ± 1 kV Common mode ± 2 kV	Differential mode ± 1 kV Common mode ± 2 kV
Conducted RF EN 61000-4-6	3V 0,15 – 80 MHz 6V in ISM band between 0.15 and 80 MHz	3V 0,15 – 80 MHz 6V in ISM band between 0.15 and 80 MHz
Magnetic fields IEC 61000-4-8	30A/m 50 Hz or 60 Hz	30A/m 50 Hz or 60 Hz
Voltage dips EN 61000-4-11	0% U_T ; 0,5 cycle at 0°, 45°, 90°, 135°	0% U_T ; 0,5 cycle at 0°, 45°, 90°, 135°, 180°, 225°, 270° and 315°

	180°, 225°, 270° and 315° 0% U_T ; 1 cycle 70% U_T ; 25/30 cycles at 0°	0% U_T ; 1 cycle 70% U_T ; 25/30 cycles at 0°
Voltage interruptions EN 61000-4-11	0% U_T ; 250/300 cycles	0% U_T ; 250/300 cycles
<i>NB: U_T is the nominal value of power voltage applied during the test.</i>		
Test specification for immunity to RF wireless communications devices		
Test frequency (MHz)	Modulation	Immunity test level (V/m)
385	Pulse Modulation: 18 Hz	27
750	FM + 5 Hz deviation: 1 kHz sine	28
710 – 745 – 780	Pulse Modulation: 217 Hz	9
810 – 870 – 930	Pulse Modulation: 18 Hz	28
1720 – 1845 – 1970	Pulse Modulation: 217 Hz	28
2450	Pulse Modulation: 217 Hz	28
5240 – 5500 - 5785	Pulse Modulation: 217 Hz	9

EQUIPOTENTIALITY

Under the head-half of the bed base you will find an equipotentiality socket, identified by the label, enabling you to connect any electromedical devices. The leads of these devices must pass through the head end and not on the side.

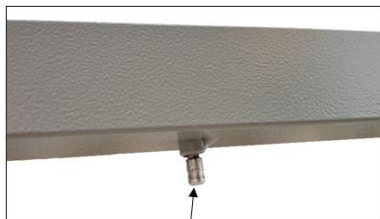

Equipotentiality

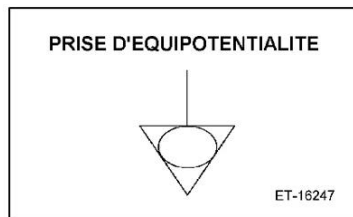

TECHNICAL CHARACTERISTICS

Noise

The measurement of the maximum audible sound power in accordance with ISO 3746 is 53 dB(A).

ELECTRICAL COMPONENTS

DESIGNATION	TYPE	PROTECTION INDEX	V/Hz
Absorbed power		300VA	
Control box	CO41	IP66	100-240 VAC 50-60 Hz
Control box	CO61	IP66	100-240 VAC 50-60 Hz
Actuator	LA27	IP66	24 VDC
Actuator	LA40	IP66	24 VDC
Lockable and backlit wired control	KH21	IP66	24 VDC
Lockable wired control	HL7x	IP54	24 VDC
Infrared control	HB23	IP21*	3 VDC
Flexible arm control	FPP	IP66	24 VDC
Mobil caregiver handset	ACO	IP66	24 VDC
Connexion box	MJB	IP66	24 VDC
Underbed light	UBL	IP66	24 VDC
Battery	BA21	IP66	24 VDC



* IP21 = Keep dry

Warning: Maximum operating time → Read the recommendations on the electrical label on the bed.

Meaning of protection ratings:

- IP66:
 - o Protection against solids: Totally protected against dust,
 - o Protection against water intrusion: Protected against strong water jets from all directions to the lance (12.5 mm nozzle, distance 2.5 m to 3 m, flow rate 100 L/min ± 5%).
- IP54:
 - o Protection against solids: Protected against dust and other microscopic residues,
 - o Protection against water intrusion: Protected against strong water jets from all directions at the lance (6.3 mm nozzle, distance 2.5 m to 3 m, flow 12.5 L/min ± 5%).
- IP21:
 - o Protection against solids: Protected against solid bodies greater than 12.5 mm,
 - o Protection against water intrusion: Protected against vertical drops of water drops.

COMPATIBLE MATTRESSES

Warning: The difference between the top of the barrier and the surface of a non-therapeutic, uncompressed mattress must be at least 220 mm. When using a therapeutic mattress, you should aim for this specification.

Respect the prescribed mattress dimensions:

- 90 cm slat base width: compatible mattress with a minimum width of 86 cm,
- 100 cm slat base width: compatible mattress with a minimum width of 96 cm,

- 120 cm slat base width: compatible mattress with a minimum width of 116 cm.

ELECTRICAL CONNECTION DIAGRAM

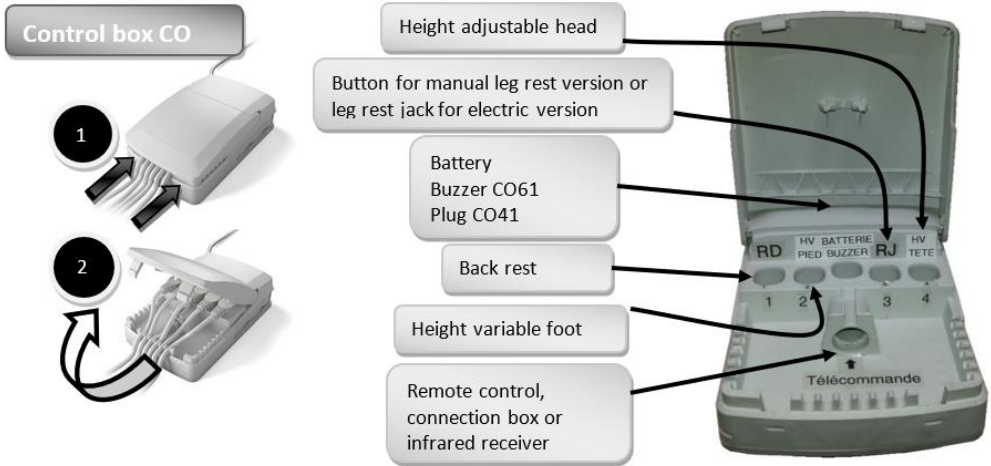

REMOTE CONTROL AERYS

CUSTOMISED VARIABLE HEIGHT POSITION

All AERYS bed controls (except Infra Rouge, for which the wired nurse keypad must be used) can be used to store a stop at a personalized variable height position (factory-set floor/sleeping surface position at 330 mm) by simultaneously pressing the two variable height buttons (5-second continuous beep).



MEMORISE A STOP ON VARIABLE HEIGHT



REMOTE CONTROL FUNCTIONS

AERYS remote control functions are described in the instructions for use.

LOCK REMOTE CONTROL FUNCTIONS

- Mechanical locking HL--

KEY LOCK A FUNCTION

KEY IN VERTICAL POSITION ? THE FUNCTION IS UNLOCKED

TURN THE KEY SLIGHTLY TO THE RIGHT TO LOCK THE FUNCTION

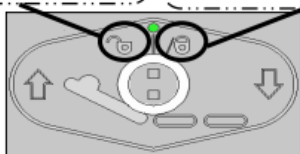

- Magnetic locking KH21

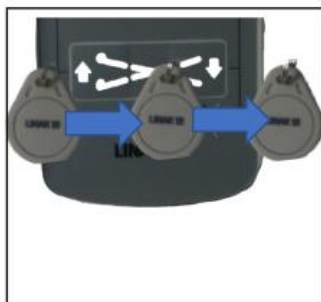

RESET OF THE AERYS BED WITHOUT LATERAL DISPLACEMENT



1

2

MAXI

RESET OF THE AERYS BED WITH LATERAL DISPLACEMENT

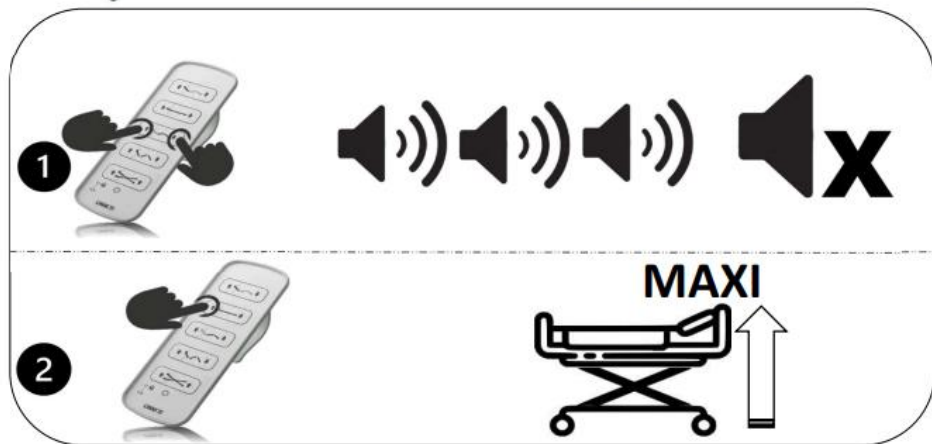

OPTION

- Option U: 3-function remote control (no Anti-Trendelenburg or Anti-Trendelenburg access),
- Option I: Infrared remote control,
- Option R: wired nurse unit,
- Option N: remote control on FPP flexible arm.

INSTALLING ACCESSORIES AND SPECIAL FEATURES

BARRIERS, SAM, AND ACCESSORIES

Please refer to the instruction for use for these products.

WALL STOP A670-00 WITHOUT BREAKING (AERYS & AERYS COMFORT)

- Version without locking

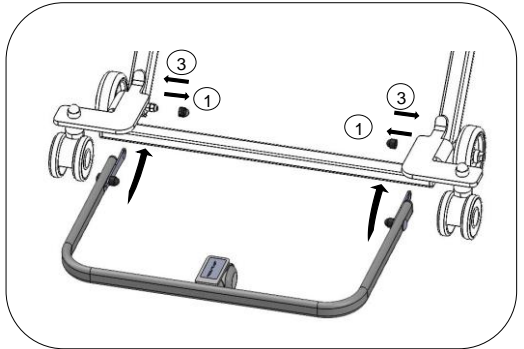
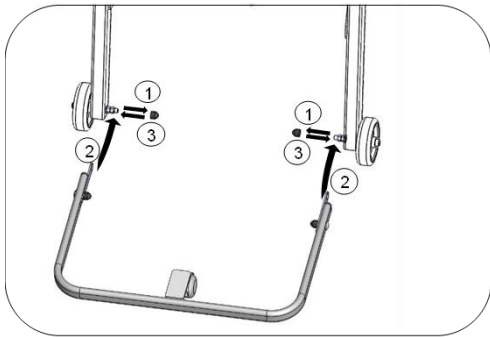

- Version with locking

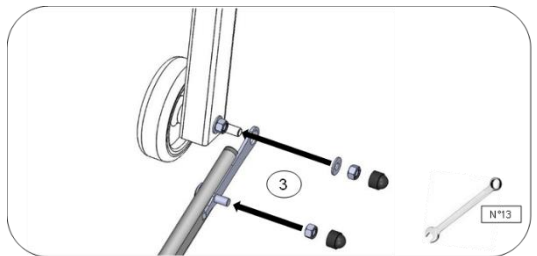
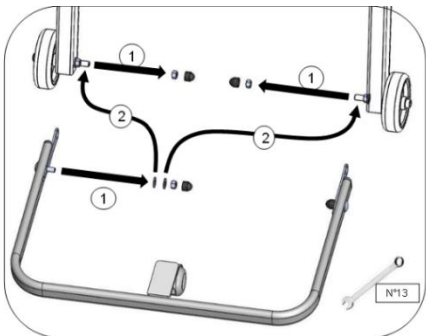

Warning: After fitting the wall stop, lower the bed against the wall to ensure that the head carriage does not move when the bed is raised, and to prevent damage.

WALL STOP A670-00B WITH OPTIONAL MASKED WHEELS (AERYS & AERYS COMFORT)

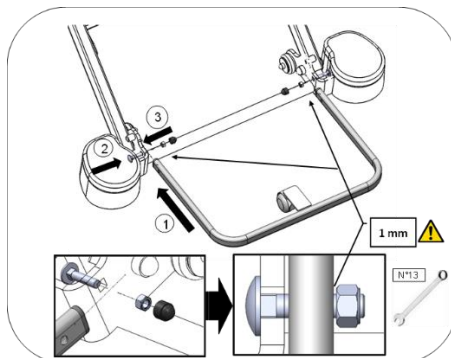

Warning: After assembling of the wall stop, set the bed in lowest position before to set it against the wall to ensure the movement of the head half base during elevation of the bed and avoid any deterioration.

WALL STOP A663-00 (AERYS XXL)

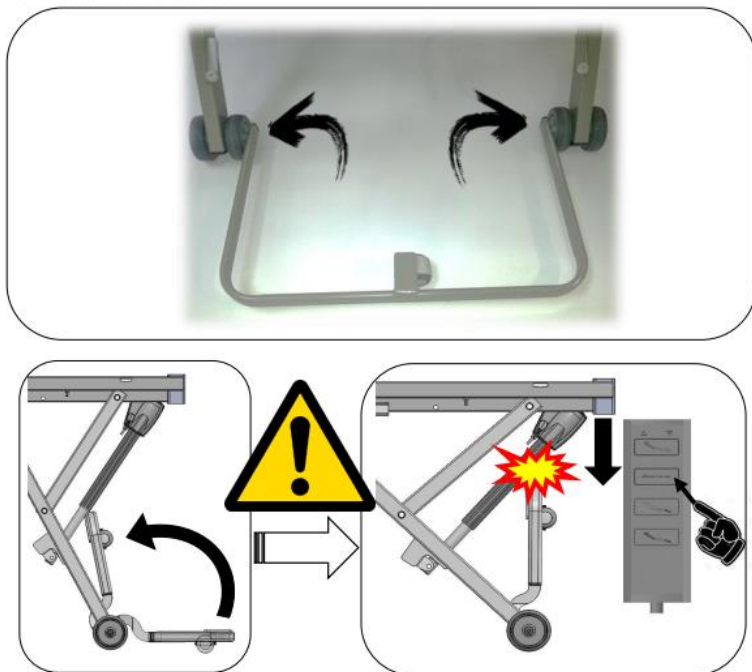

TRENDELENBURG / BACK TILT

To activate the Trendelenburg or forward tilt position, press the corresponding button on the remote control of the bed.

When you pass to forward tilt in Trendelenburg or conversely, a stop is made in a horizontal position. To resume the movement, release the button and press again or staying press 3 seconds.

WINNCARE France recommends leaving a space of at least 50 cm between the headboard and the wall in the case of use of the Trendelenburg position with a bracket or IV pole.

Warning: The Trendelenburg position should always be prescribed and under medical supervision. When the bed is placed in low position, make sure that there are no objects and no parts of the patient's or care's body caught between the bed, the boards, the accessories, and the ground or between the boards and half bases or between the half cross braces.

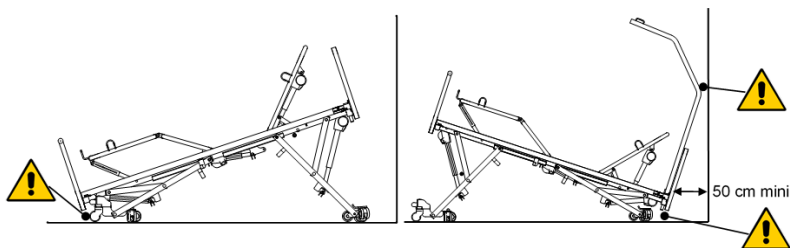

- AERYS & AERYS COMFORT

Forward tilt 17°

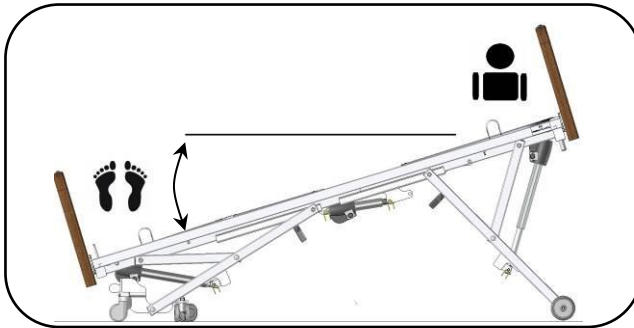

Trendelenburg 5°

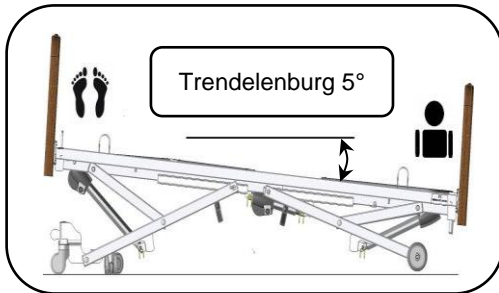

Trendelenburg 12°

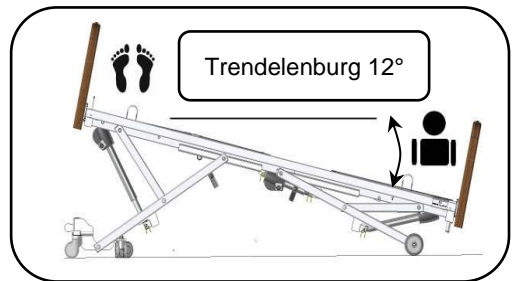

Upon activation of the function Trendelenburg, 1 stop occurs 5°, to reach the position Trendelenburg 12°. To resume the movement, release the button and press again or staying press 3 seconds. The forward tilt position occurs at 17°.

- AERYS XXL

Forward tilt 15°

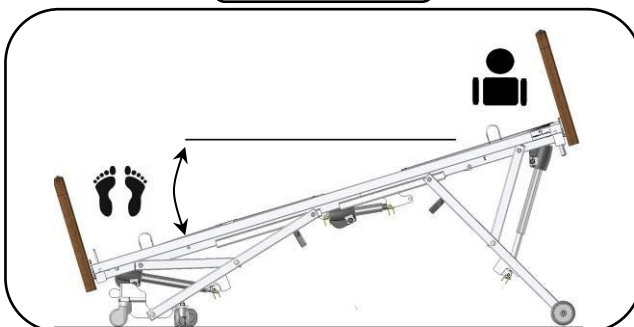

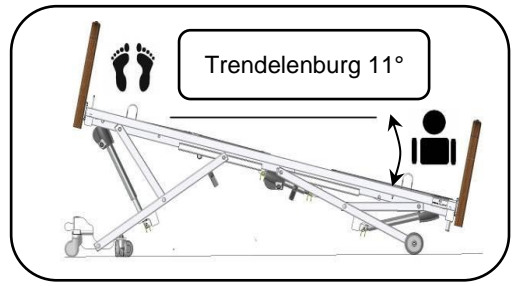
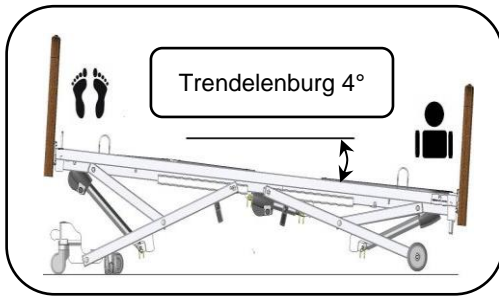

Upon activation of the function Trendelenburg, 1 stop occurs 4°, to reach the position Trendelenburg 12°. To resume the movement, release the button and press again or staying press 3 seconds. The forward tilt position occurs at 15°.

POWER SUPPLY UNIT INITIALIZATION

The power supply unit may fail of its own accord (incorrect connection, cable fault, cylinder fault). In this case, movement is impossible, and the box emits a short, discontinuous beep when a remote-control button is pressed.

It is therefore necessary to reset the electrical unit.

ELECTRICAL SYSTEM INITIALIZATION (ALL OPTIONS WITHOUT SIDE SHIFT OPTION)

Simultaneously press the two buttons of back rest and hold until the end of a long and discontinuous beep (all options without side shift option).

Squeeze out the height variable actuators to the maximum (initialization of actuators).

ELECTRICAL SYSTEM INITIALIZATION (OPTION T)

Simultaneously press the two buttons of electric folding legs and hold until the end of a short and discontinuous beep (only on side shift option).

Squeeze out the height variable actuators to the maximum (initialization of actuators).

USE OF NIGHT LIGHT (OPTION J)

Possibility with all remote controls to use the night light fastened under the bed base.

The function is switched on and off by simply pressing the back-rest function.

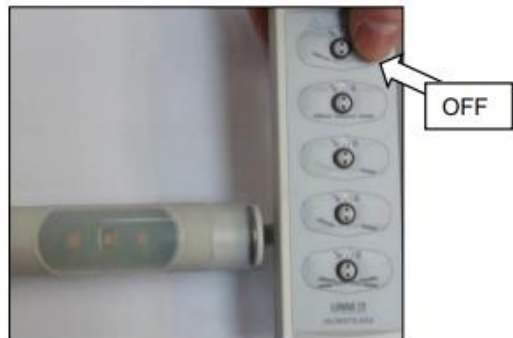
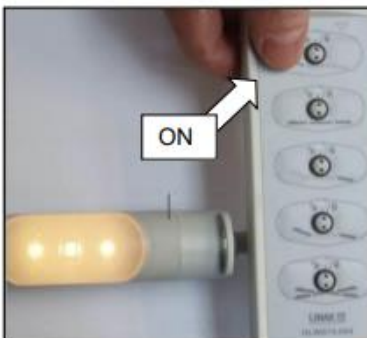



OPERATION OF THE NIGHT LIGHT (option)

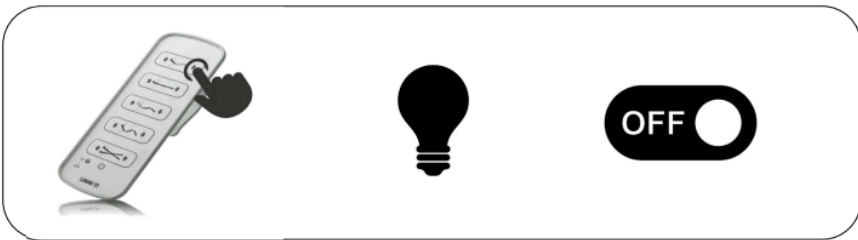

ANGLE LIFTING POLE AND IV STAND

In case of psycho-behavioural problems of the patient, it is necessary to fix the stem to the bed with the screw and the washer provided.

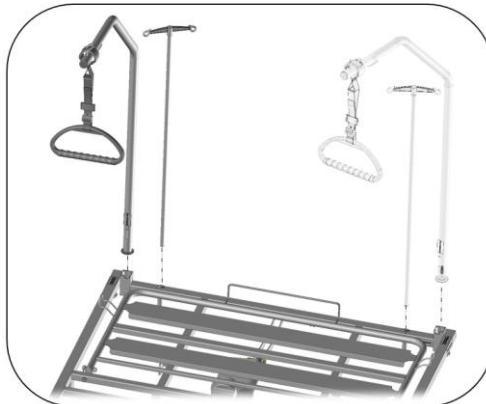

Specific features of the A622-00:

Maximum patient weight is 75 kg.

- Precautions for use of the angle lifting pole
 - Replace the handle immediately if you notice any damage to the handle itself or its components.
 - Ensure that the height of the handle is correctly adjusted in relation to the patient.

- Keep the handle away from sources of high heat such as cigarettes or open flames and observe the environmental conditions specified here.
- The handle must not be rotated several times around the vertical axis (more than 180°) when hooked up.

➤ Height adjustment

The length can be adjusted by adjusting the strap using the plastic buckle. The handle must always be unloaded.

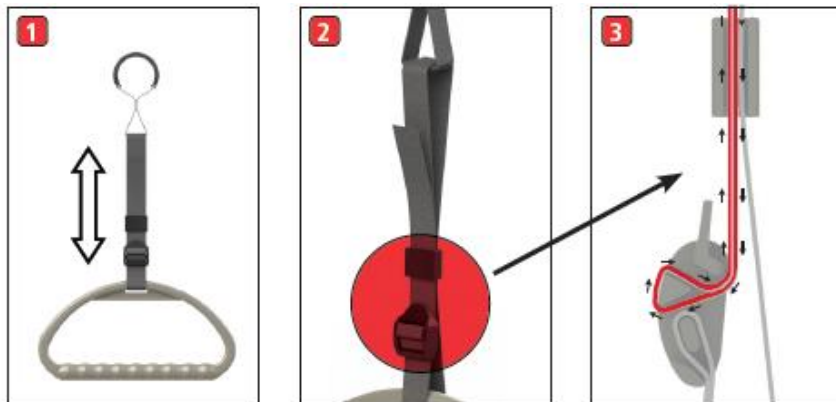

Side view: plastic buckle + strap.

➤ Maintenance

The recommended lifetime of the stem handle is influenced by many factors, such as temperature, humidity, UV radiation, contact with chemical substances, stress, etc. Careless handling can also cause premature wear and ageing of the plastics and/or the textile strap, without the manufacturer having any direct influence on this. Careless handling can also cause wear and premature ageing of the plastics and/or textile webbing, although the manufacturer has no direct influence on this. We therefore recommend replacing the stem handle after 5 years, even if no external damage is visible.

The recommended service life and maintenance intervals shown below apply from the date of installation.

Maintenance intervals:

- Function test: every three months,
- Check of plastic parts: every three months,
- Check straps and seams: every three months,
- Checking the anti-slip protection: once a year,

If the function test or maintenance reveals serious faults, the product must be replaced immediately.

TROUBLESHOOTING GUIDE

DEFAULT	POSSIBLE CASE	HELP
The whole bed is not working	The bed is not electrically powered	Check the electrical connection (Green power LED on control box)
	The remote control is fully locked	Unlock the remote control
		Remove the rear cover Check batteries

	The infrared remote control is not powered or is not connected to the receiver.	Reverse the small contactor on top of the remote control
	One or more cables are not connected properly	Check the correct connection of the electrical cables Check for the presence of anti-tear clips at the cable connections
	One or more cables are cut or pinched	Check the condition and passage of electrical cables
	An electrical element is defective	Contact after sales service
The entire bed does not work, a short and discontinuous beep sounds when a key is pressed on the remote control	The control box is faulty	Do a reset of the control box (§ Specific use) or contact after sales service if a reset is impossible
A continuous beep sounds when a key is pressed on the remote control	The backup battery has reached its last cycle	Reconnect the bed to the mains to recharge the battery
A long and discontinuous beep is emitted when the bed is in the high position (normal event)	The bed is no longer braked (position on wheels, normal event)	Press down on the variable height to remove the wheels (normal use)
The selected function of the bed does not work	The function is locked on the remote control	Unlock the function on the remote control
	The movement has reached the stop	Operate the opposite direction of movement on the remote control
	An external element blocks the mechanism	Remove the blocking element
	One or more cables are not connected properly	Check the correct connection of the electrical cables Check for the presence of anti-tear clips at the cable connections
	One or more cables are cut or pinched	Check the condition and passage of electrical cables
	An electrical element is defective	Contact after sales service
The selected function of the bed is interrupted during movement	The movement has reached the stop	Operate the opposite direction of movement on the remote control
	The movement has reached a memorized position (normal event)	Release the button on the remote control and then press (normal cycle)

	An external element blocks the mechanism	Remove the blocking element
Bed cannot be moved / moves with difficulty	The putting on wheels is not carried out or incomplete	Press the remote control to put the bed on its wheels until the movement stops
	Directional wheel hinders movement	Put the pedal in the 4-wheel free position
	An external element blocks the mechanism	Remove the blocking element
	One or more wheels are defective	Contact after sales service

MAINTENANCE

Warning: No maintenance should be done in the presence of a patient on the bed.

IDENTIFICATION

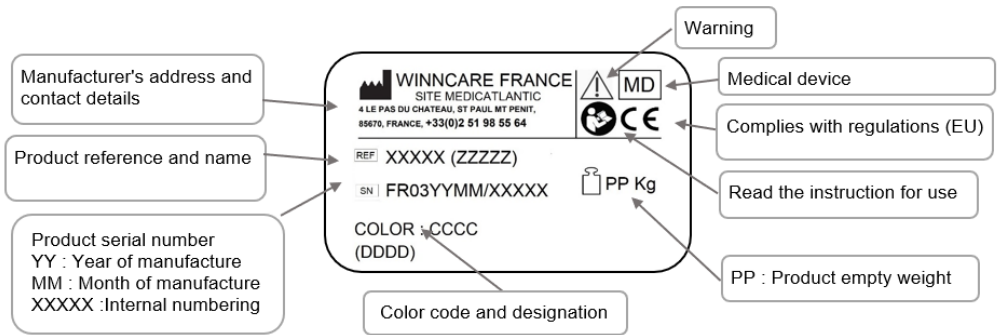

INSTRUCTIONS FOR DISMANTLING THE MOTORS

Warning: Unplug the device before dismantling.

- Dismantle when the bed is empty or in the side position.
- If dismantling in any other position, keep a firm hold of the moving parts to avoid any shearing.
- Unblock the safety clips (1), unplug the motor leads, and remove them from the securing seals.
- Put the motors back in place and put in the same direction as at the beginning.

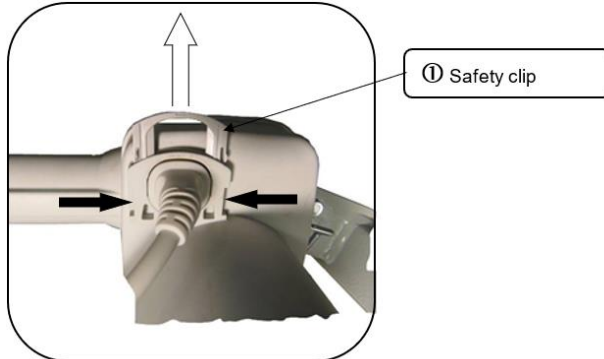

MAINTENANCE

Quality control of medical beds and its accessories will be made by technical staff or trained biomedical and taking into account the normal conditions of use specified in the user guide.

The bed must be available to perform all quality control at least once a year, but also on special request and corrective maintenance on the performance that could be affected by the intervention. However, to save time this may be associated with preventive maintenance. In this case, it is not useful to make a further examination of already controlled performance.

RECOMMENDATIONS for PREVENTIVE MAINTENANCE:

Preventive maintenance should be carried out in accordance with our specifications and at least once a year by the organisation or person who installed the bed.

Between two maintenance sessions and at least once a year, the following should be carried out:

- Verification that the electrical leads are connected all along the metal jambs to prevent shearing of these leads when the variable height is being activated.
- Verification that all the electrical leads and plugs are in good condition. Replacement if there is the slightest alteration (wear, shearing, damage, etc.).
- Verification of the external appearance (traces of damp and good overall condition of protective covers in particular) and that the motors and jacks function properly.
- Verification that the bed is in good working order (test all functions).
- Verification that the frame, bed base and mechanical joints are all in good condition.

When maintenance is carried out at the patient's home as part of a long-term contract, the installer must also:

- Check that the bed is properly installed (check to see that there hasn't been any modification contrary to the safety instructions made by the user since the bed's installation).
- Remind the users of the safety instructions.
- All installation and preventive maintenance operations must be recorded. See table model below. This record must be kept in a designated area throughout the bed's lifetime.

MEDICAL BEDS CONTROL SHEET

HELP WITH EQUIPMENT
MAINTENANCE

Send form

Reset form

Save

FORM 110

17/07/2024

ANNUAL MAINTENANCE OF MEDICAL BEDS

IDENTIFICATION		ESTABLISHMENT	
Type model / Trademark :	<input type="text"/>	<input type="text"/>	
Date of manufacture :	<input type="text"/>		
Serial or park number :	<input type="text"/>		
Application Environment	1 <input type="checkbox"/> 2 <input type="checkbox"/> 3 <input type="checkbox"/> 4 <input type="checkbox"/> 5 <input type="checkbox"/>		

VISUAL CONTROL		Not applicable	Congruent	Improper
Identification - label			<input type="checkbox"/>	<input type="checkbox"/>
General cleanliness			<input type="checkbox"/>	<input type="checkbox"/>
Condition and attachment of head and footboards		<input type="checkbox"/>	<input type="checkbox"/>	<input type="checkbox"/>
Lifting pole (fastening, strap, winder, ...)		<input type="checkbox"/>	<input type="checkbox"/>	<input type="checkbox"/>
Sleeping surface (bedspring)			<input type="checkbox"/>	<input type="checkbox"/>
Verification of tightenings, axle, circlips + diverse nuts and bolts, pins, pivot			<input type="checkbox"/>	<input type="checkbox"/>
Remote controls (displays, lights and locking)			<input type="checkbox"/>	<input type="checkbox"/>
Bed specific side rails				
Space between head of bed and siderail (< 60 mm)*		<input type="checkbox"/>	<input type="checkbox"/>	<input type="checkbox"/>
Space between the half siderails (< 60 or > 318 mm)*		<input type="checkbox"/>	<input type="checkbox"/>	<input type="checkbox"/>
Condition, mounting direction, adaptation to bed ...		<input type="checkbox"/>	<input type="checkbox"/>	<input type="checkbox"/>

FUNCTIONAL CONTROL		Not applicable	Congruent	Improper
Mobile parts (variable height, backrest, legrest, Trendelenburg...)			<input type="checkbox"/>	<input type="checkbox"/>
Remote controls including functions locking			<input type="checkbox"/>	<input type="checkbox"/>
Castors (pivoting, rolling)			<input type="checkbox"/>	<input type="checkbox"/>
Braking			<input type="checkbox"/>	<input type="checkbox"/>
Fixing of siderails and locking in high position (closed)		<input type="checkbox"/>	<input type="checkbox"/>	<input type="checkbox"/>
Absence of sound disturbances (squeaking, lubrications)			<input type="checkbox"/>	<input type="checkbox"/>

CPR CONTROL		Not applicable	Congruent	Improper
Retracting headboard in case of emergency (App. env. 1 & 2)		<input type="checkbox"/>	<input type="checkbox"/>	<input type="checkbox"/>
Emergency flattening of backrest			<input type="checkbox"/>	<input type="checkbox"/>

ELECTRICAL CONTROL		Not applicable	Congruent	Improper
Status of electrical cables, plugs and connectors			<input type="checkbox"/>	<input type="checkbox"/>
Status of electrical equipment (controlbox, actuators,...)			<input type="checkbox"/>	<input type="checkbox"/>
Recurrent test following standard NF EN 62353 (see test report for more details)		<input type="checkbox"/>	<input type="checkbox"/>	<input type="checkbox"/>

Obsolescence : New 1 2 3 4 5 Decrepit

<p>Observations</p> <div style="border: 1px solid gray; height: 100px; width: 100%;"></div>	<p>Made on : <input type="text"/> Name : <input type="text"/></p> <div style="display: flex; justify-content: space-between;"> <div style="width: 45%; border: 1px solid gray; height: 60px; margin-bottom: 5px;"></div> <div style="width: 45%; border: 1px solid gray; height: 60px; margin-bottom: 5px;"></div> </div> <p style="font-size: small; margin-top: 5px;">Signature and stamp of technician Signature of customer</p>
---	--

*following standard IEC- 60601-2-52

CLEANING AND DISINFECTION

High pressure cleaning, or jet cleaning is prohibited.

Unplug the mains lead.

Check that all the electrical parts are connected. All the sockets of the supply box must be used or filled, otherwise its watertightness is not guaranteed.

Clean the electric covers of the jacks and wired control by means of a mop impregnated with a detergent-disinfectant product.

The medical bed is a non-critical appliance requiring “Low Level” disinfection.

We draw your attention to the fact that the recommendations below are drawn up according to the rules of good practice but are not a protocol. Contact the hospital hygiene department.

➤ **AIM**

To recondition the bed and prevent the transmission of germs from one patient to another.

To eliminate all organic soiling by:

- Physical action (cleaning),
- Chemical action (disinfection).

➤ **INDICATION**

Physical and bacteriological cleanliness of the bed and its accessories.

➤ **EQUIPMENT**

- Microfiber wipes.
- Detergent or Detergent-Disinfectant (Surface DD with CE mark) and surface Disinfectant (Chlorine substances, alcohol base < 30%).

Warning: undiluted DD products falling under the status of biocide pursuant to Regulation 528/2012 relating to the availability on the market and the use of biocide products and chloride bleach shall not be used pure. A remanence time must be applied according to the disinfectant manufacturer’s instructions (the drying time without human presence is often the same as the remanence time) (Refer to the instruction manual)

- SANIVAP steam appliance with accessories.

➤ **TECHNICAL**

- Daily maintenance with a surface DD product in one operation.
- Maintenance when the patient leaves, or periodically, by the process known as Bio cleaning observing the 3 operations:
 - Cleaning is done by means of a cloth soaked in a surface detergent or Detergent-Disinfectant (DD) solution,
 - Rinsing is done with cloth rinsed in clean water,
 - Disinfection is done by means of a cloth soaked in a surface disinfectant solution.
- Specific maintenance by specialist contractors after removal of the bed from the establishment:
 - Bio cleaning operation, or,
 - Steam cleaning (accessory with microfiber band) of the flat surfaces and the base slats. Change the washing mops regularly to prevent water accumulating. Clean the parts that are difficult to access with a steam nozzle (wheels, hinges after opening, corners, etc.). For tubes, use the steam nozzle with a microfiber cloth. Never direct the nozzles onto electrical boxes or actuators.
 - Dry hinges with compressed air.

- Attention: Disinfect jacks, electrical boxes and remote controls with a microfiber cloth soaked in disinfectant.

Do not rinse or wipe.

- Check the operation of all the bed functions,
- Repair, if necessary,
- Pack in thermoplastic film.

Warning:

- In the event of additional precautions (Contact precautions, Droplets or Air), apply the measures recommended by the hospital hygiene department,
- The use of a Javel water solution of more than 5000ppm (0.5% of active chlorine) should be justified by a microbiological risk and only applied for the required time (Risk of ageing of some materials, especially their colour),
- The concentration of alcohol-based surface disinfectant solutions should be less than 30%.

Note: The use of the terminal disinfection process is compatible with the medical bed and its accessories.

SCRAPPING

The product must be scrapped if the main requirements are no longer met, particularly when the product no longer has its original characteristics and has not been subject to corrective action during the manufacturing process.

Measures should therefore be taken to ensure that the bed is no longer used for the purpose it was originally intended.



The crossed-out bin symbol indicates that the electrical elements of the WINNCARE France product are considered to be Electrical and Electronic Equipment (EEE), subject to EU Directive 2012/19 / EU on the Selective sorting of electrical and electronic waste (DEEE); batteries and accumulators that can be used in these products fall within the scope of the European Union and Council Directive 2006/66 / EC of 6 September 2006 on batteries and accumulators and waste batteries and accumulators. The complete product and / or the easily detachable electrical part and the batteries / accumulators contained in WINNCARE France products must therefore be separately sorted in the countries of the European Union.

For France and DOM-TOM, WINNCARE France provides you with suitable recycling solutions for these Electrical and Electronic Equipment (EEE), information is available on the website <https://www.winnicare.fr> or by contacting WINNCARE France at n ° +33 (0)4.66.02.15.15.

WINNCARE France also encourages you to limit the possible effects of waste on the environment and public health in all other countries, by complying with local selective sorting laws, separating waste from Electrical and Electronic Equipment (EEE), as well as batteries and accumulators.

SPARE PARTS

A list of spare parts is available from WINNCARE France after-sales service:

- Mail: sav@winnicare.fr



WINNCARE France

4, Le Pas du Château
85670 SAINT-PAUL-MONT-PENIT
FRANCE



WINNCARE France

4, Le Pas du Château
85670 SAINT-PAUL-MONT-PENIT
FRANCE

Tél. : +33 (0)4.66.02.15.15
Fax. : +33 (0)4.66.02.15.00
Email: contact@winnicare.fr
www.winnicare.com

